

# TG-S

The TG-S type spring return pneumatic actuator is suitable for on/off control for medium and large sized valves. With an optional positioner, it can also be used for flow control. Air pressure and the spring force the piston inside the cylinder into a linear reciprocating motion, causing the pin coupled to the piston rod to rotate the output shaft.

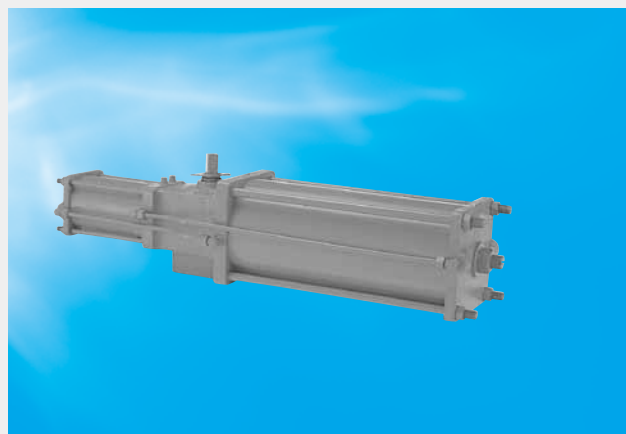

TG-S Specifications				
	TG-10S	TG-12S	TG-14S	TG-20S
Torque (N·m) (0.4MPa)	260	600	1250	3250
Supply pressure (MPa)	0.4~0.7 <sup>*1</sup>			
Body shell max (MPa)	1.0			
Port size	Rc3/8			Rc1/2
Rotating angle	-3 to +93°			
Operating fluid	Dry air			
Working temperature range (degrees)	0 to 80 degree C <sup>*2</sup>			
Rotating speed range (sec.)	4 to 20	6 to 20	11 to 20	18 to 40
Painting	Epoxy primer finish (Munsell N7)			

※ Supply pressure: 0.4MPa, without accessories

※1 If used for the TRITEC(TT1, TT2) with over 0.5MPa supply pressure, and forecasting over 10,000 times operation. Please ask us about cylinder specifications.

※2 Please ask us when used at working temperature of more than 60 degree C.

## TG-S Outer Dimensions

**3K**

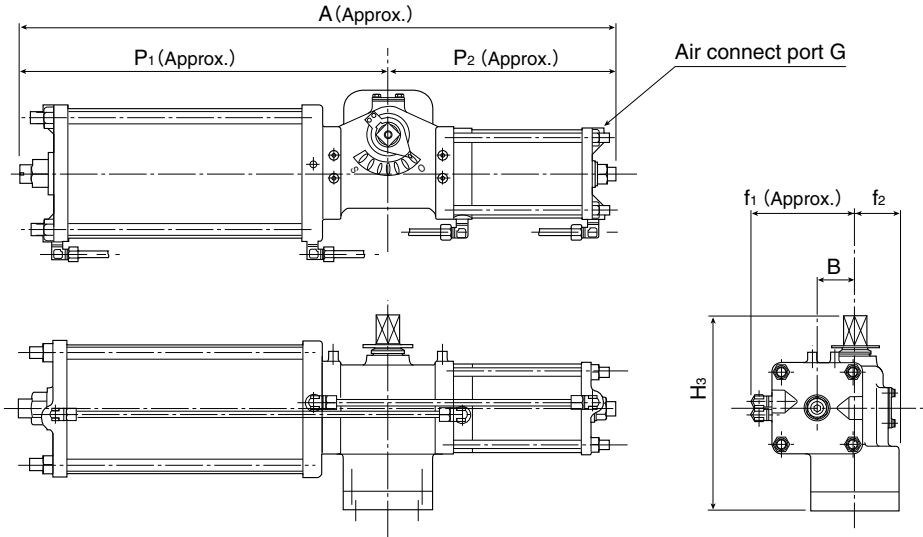

**3U**

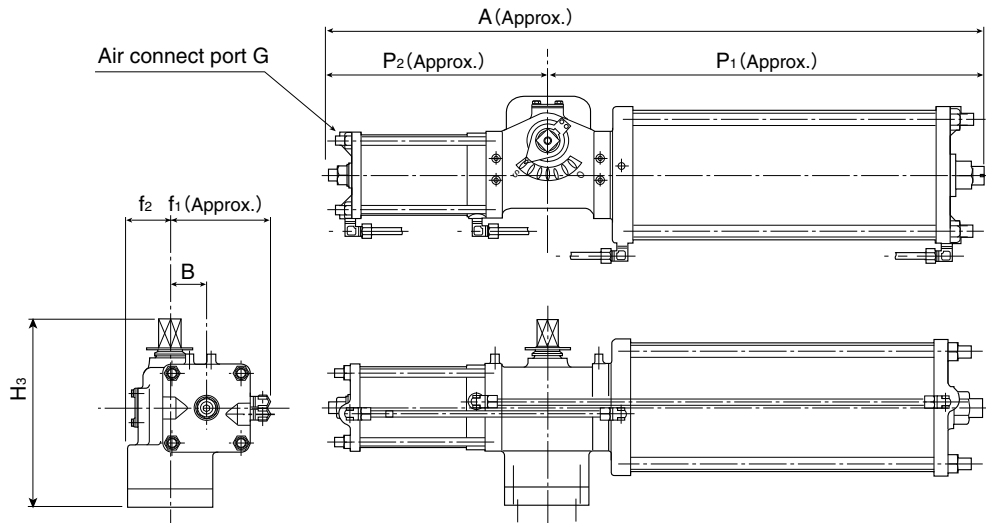

## TG-S Dimensions

Type	Dimension (mm)								Approx. Mass (kg)
	A	P1	P2	H	f1	f2	B	G	
TG-10S	945	585	360	307	165	70	60	Rc3/8	50
TG-12S	1080	720	360	307	206	70	60	Rc3/8	95
TG-14S	1255	865	390	340	257	70	67	Rc3/8	191
TG-20S	1655	1095	560	474	348	83	95	Rc1/2	402

<b>Actuator</b>
<b>New ELMY 4I</b>
<b>New MICOM ELMY II 4I</b>
<b>PMK-SRF 4K</b>
<b>SRJ 4J</b>
<b>LTKD 4L</b>
<b>New T-DYNAMO 7E/7F/7G</b>
<b>TGA 3A</b>
<b>TG-S 3K/3U</b>
<b>3C</b>
<b>Diaphragm 6X/6W/6Z/6A/6B</b>
<b>Hydraulic cylinder 3H</b>
<b>Manual Actuators 1T/1J/2U/2I/2S/2G/2R</b>

TG-S Operation principle

As shown in the picture on the right, the chamber A<sub>1</sub> is connected to the chamber A<sub>2</sub> with copper tubes. The same is true for chamber B<sub>1</sub> and B<sub>2</sub>. Operating air is supplied through port "O" and fills chambers B<sub>1</sub> and B<sub>2</sub>. The air moves pistons ① and ② to the right, so that the spring is tensed. when thrust is transmitted to the pin on the piston rod to give the output shaft a force to produce counter-clockwise rotation through the arm, which rotates the shaft counter-clockwise. Residual air in chambers A<sub>1</sub> and A<sub>2</sub> is exhausted through port "S". During air failure mode, the spring forces the piston ② to move left, when thrust is transmitted to the pin on the piston rod to give an output shaft a force to produce clockwise rotation through the arm, which rotates the shaft clockwise.

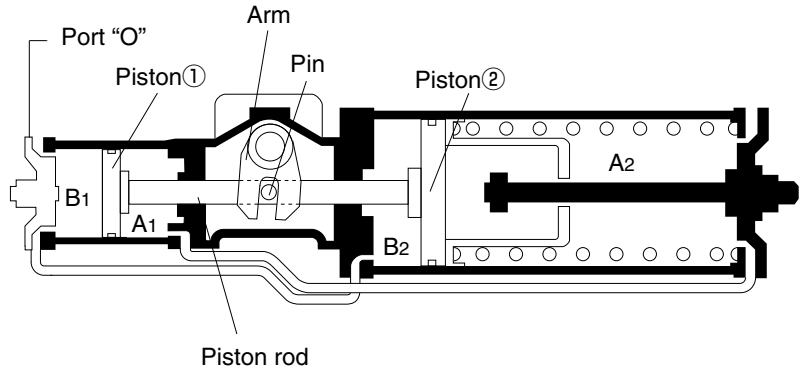

TG-S Air consumption

Type	Cylinder capacity ( ℓ )
TG-10S	3.59
TG-12S	6.36
TG-14S	12.56
TG-20S	36.29

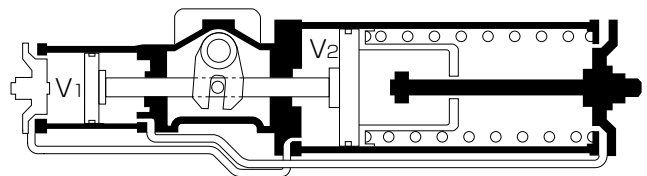

(1) Required air consumption

Double-acting type	$VD = (A+B) \left( \frac{P+0.1013}{0.1013} \right) N$	VD : Double-acting type cylinder air consumption (Nℓ)
Single-acting type	$VS = (A \text{ or } B) \left( \frac{P+0.1013}{0.1013} \right) N$	VS : Single-acting type cylinder air consumption (Nℓ)
		A, B: Cylinder capacity (ℓ)
		P: Working pressure (Mpa)
		N: Operating frequencies in a given time (1 round trip=1)

(2) Air consumption within a unit time

Double-acting type	$CD = \frac{VD}{t}$	CD: Double-acting type cylinder air consumption (Nℓ/sec)
Single-acting type	$CS = \frac{VS}{t}$	CS: Single-acting type cylinder air consumption (Nℓ/sec)
		t: Unit time (sec)

Remark: The compressor should have a larger capacity than the air consumption calculated in above in (1) and (2).

## TGS Output Torque Curve

### ● Single-acting type (spring returned type)

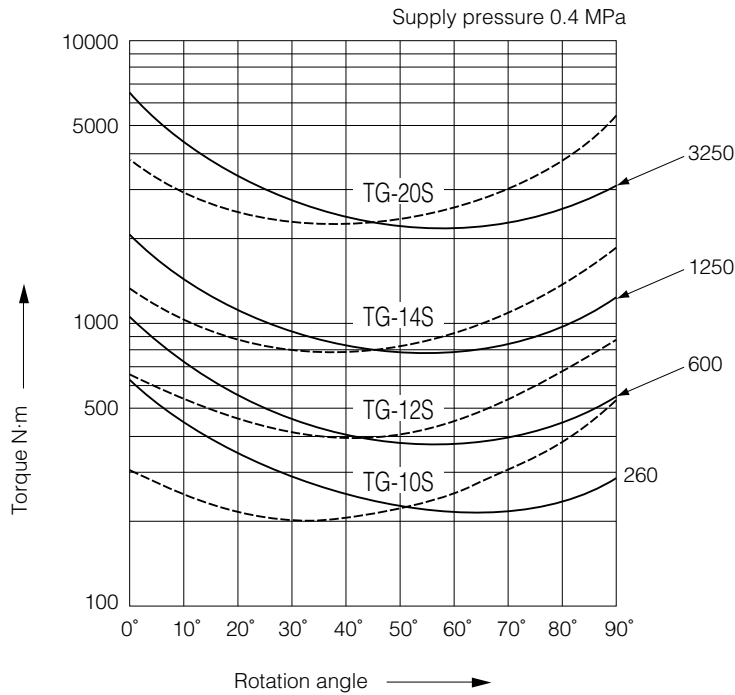

Notes :

- — Lines show output torque curve by actuator
- - - - Lines show output torque for spring force (air less)
- The table shows the torque at an operating air pressure of 0.4 MPa.

## TG-S Output Torque

(N·m)

Type	Supply pressure (0.4 MPa)		Spring power	
	0°	90°	0°	90°
TG-10S	600	260	260	600
TG-12S	1050	600	600	1050
TG-14S	2000	1250	1250	2000
TG-20S	6500	3250	3250	6500

<b>Actuator</b>
<b>New ELMY</b> 4I
<b>New MICOM ELMY II</b> 4I
<b>PMK-SRF</b> 4K
<b>SRJ</b> 4J
<b>LTKD</b> 4L
<b>New T-DYNAMO</b> 7E/7F/7G
<b>TGA</b> 3A
<b>TG-S</b> 3K/3U
<b>3C</b>
<b>Diaphragm</b> 6X/6W/6Z/6A/6B
<b>Hydraulic cylinder</b> 3H
<b>Manual Actuators</b> 1T/1J/2U/2I/2S/2G/2R

## TG-S Accessories

Accessory	Type	Manu- facture	Part No.	Double-acting type			
				TG-10S	TG-12S	TG-14S	TG-20S
Non explosion-proof, solenoid valve	Single solenoid	Kuroda	PCS2408-MC	★	★	★	—
	Five-port/	Kuroda	PCS2415-MC	—	—	—	★
Explosion-proof, solenoid valve	Single solenoid	Kaneko	MB15G-TMS	○	○	○	○
	Five-port/			○	○	○	○
Filter regulator		SMC	AW30-03B-X490	○	○	○	—
		SMC	AW40-04B-2	—	—	—	○
Limit switch	Non explosion-proof	Tomoe	TMS-BOX	★	★	★	★
		Azbil	1LS1-J	○	○	○	○
		OMRON	WLCA2	○	○	○	○
	Explosion-proof	Azbil	1LX5001	○	○	○	○
		Azbil	VCX-5003	○	○	○	○
Proximity switch	M18 shielded	OMRON	E2E-X7D1-N	★	★	★	★
	M18 non-shielded	OMRON	E2E-X14MD1	○	○	○	○
	M30 shielded	OMRON	E2E-X10D1-N	○	○	○	○
Positioner	Electro-pneumatic	SSS	TCE2000	★	★	★	★
		SMC	TP8100	○	○	○	○
		Azbil	AVP300	○	○	○	○
	Pneumatic-pneumatic	SMC	IP5100	○	○	○	○
Manual operating unit	Manual screw handle	Tomoe	—	○	○	○	
Speed controller		SMC	AS3000-03	★	★	★	—
		SMC	AS4000-04	—	—	—	★
Silencer		SMC	AN200-02	○	○	○	○
		SMC	AN300-03	○	○	○	○
		SMC	AN400-04	—	—	—	○
Lock-up valve		SMC	IL211-02	○	○	○	○

**Remarks:**

1. Symbols in table mean the following: ★: Standard accessory, ○: Installable, —: Un-installable
2. This table shows typical accessory combinations. Accessories not shown in this table can also be installed.  
For details please consult us.

## TG-S Solenoid valves

### ■ Purpose

The purpose of a solenoid valve is to use electrical signals to remotely change the air flow to operate the valves.

### ■ Standard specifications

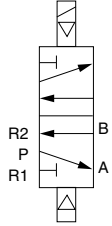
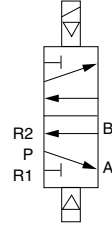
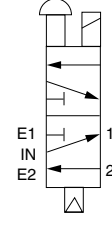
Item	Five-port/2-position, non explosion-proof, solenoid valve (single solenoid)	Five-port/2-position, non explosion-proof, solenoid valve (single solenoid)	Five-port/2-position, explosion-proof, solenoid valve (single solenoid)
Type	PCS2408-MC	PCS2415-MC	MB15G-10AE12PU-TMS
Manufacturer	Kuroda	Kuroda	Kaneko
JIS symbol			
Applicable cylinder type	TG-10S to 14S	TG-20S	TG-10S to 20S
Air connection port size	Rc3/8 (IN,OUT) Rc1/4 (EXH)	Rc1/2 (IN,OUT) Rc3/8 (EXH)	Rc3/8 (IN,OUT) Rc1/4 (EXH)
Effective sectional area	30mm <sup>2</sup>	70mm <sup>2</sup>	11mm <sup>2</sup>
Rated voltage	AC100V/110V 50/60Hz AC200V/220V 50/60Hz DC24V	AC100V/110V 50/60Hz AC200V/220V 50/60Hz DC24V	AC100V, AC200V 50/60Hz AC110V, AC220V 60Hz DC24V
Class of insulation	—	—	d2G4
Wiring method	Conduit terminal	Conduit terminal	Conduit terminal
Conduit entry	G1/2	G1/2	G1/2
Manual operating	Non lock bush type	Non lock bush type	Manual button lock type
Operating temperature	−5 to 50 degrees C	−5 to 50 degrees C	−20 to 60 degrees C
Weight	0.46kg	0.85kg	1.24kg

Remark: The above are standard TOMOE-compatible solenoid valves. It is also possible to install solenoid valves other than those listed above such as a port solenoid valve. For details, please consult us.

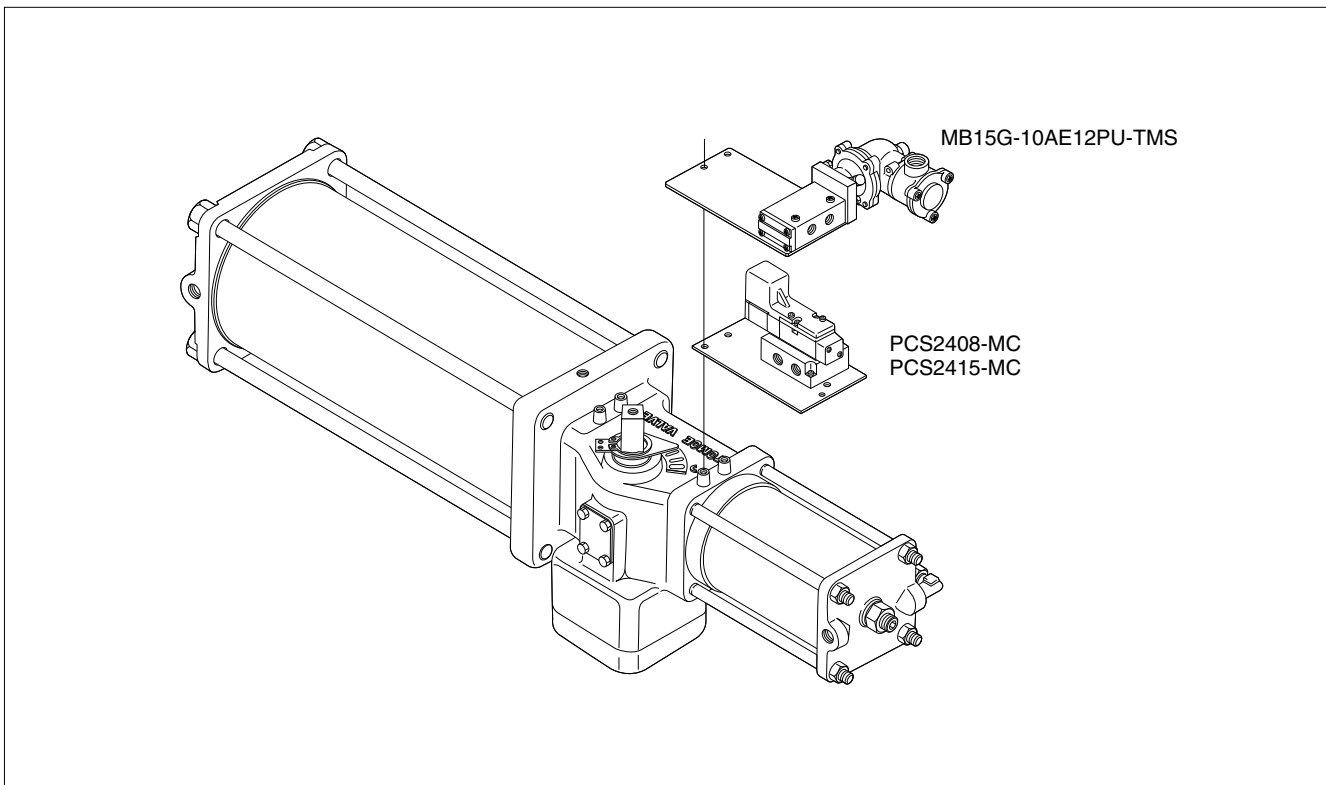

- Actuator**
- New ELMY 4I**
- New MICOM ELMY II 4I
- PMK-SRF 4K**
- SRJ 4J**
- LTKD 4L**
- New T-DYNAMO 7E/7F/7G
- TGA 3A**
- TG-S 3K/3U**
- 3C**
- Diaphragm 6X/6W/6Z/6A/6B**
- Hydraulic cylinder 3H**
- Manual Actuators 1T/1J/2U/2I/2S/2G/2R**

## TG-S Filter regulator (Decompression valve with filter)

### ■ Purpose

Filter regulators are used to eliminate oil, water, and dust from the operating air in order to protect pneumatic accessories (solenoid valve and cylinder, etc.) and to keep operating pressure at an adequate and constant level (about 4 to 5 K).

### ■ Standard specifications

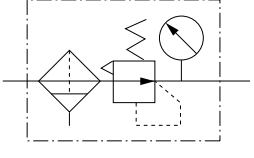
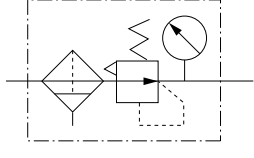
Type	AW30-03B-X490	AW40-04B-2
Manufacturer	SMC	SMC
JIS symbol		
Applicable cylinder type	TG-10S to 14S	TG-20S
Set pressure range	0.05 to 0.85MPa	0.05 to 0.85MPa
Pressure gauge connection port	Rc1/8	Rc1/4
Operating temperature	-5 to 60 degrees	-5 to 60 degrees
Air connection port size	Rc3/8	Rc1/2
Attachment	5 $\mu$ m	5 $\mu$ m
Option	Auto drain for low and high temperatures	Auto drain for low and high temperatures
Weight	0.79kg	1.52k

Remark: The above are standard TOMOE-compatible filter regulators. It is also possible to install filter regulators other than those listed above. For details, please consult us.

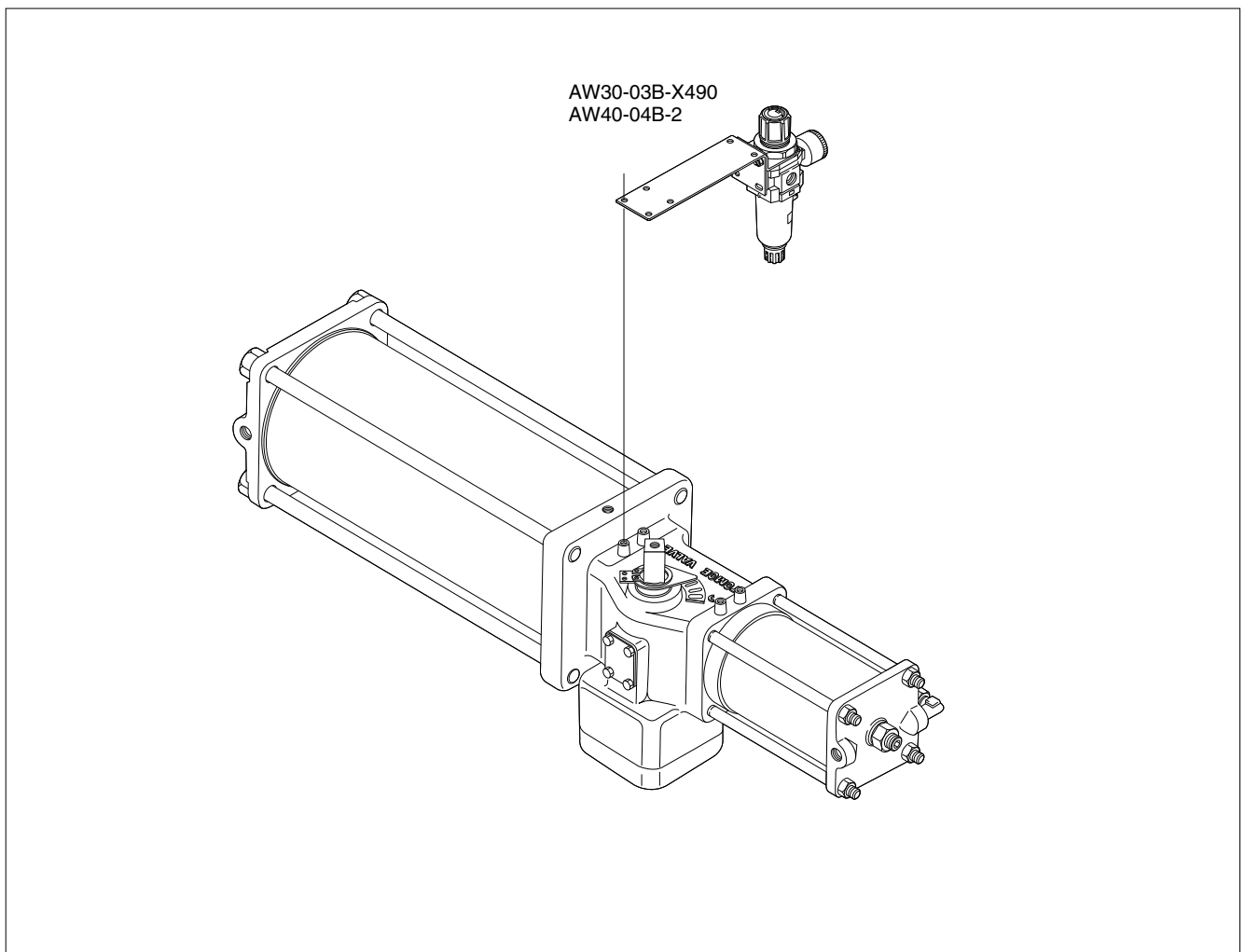

## TG-S Limit switches

### ■ Purpose

Limit switches are used to convert the valve position (full close, full open, half open) into electric signals for lamp indication at a remote location.

### ■ Standard specifications

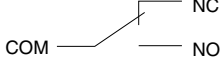
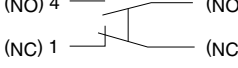
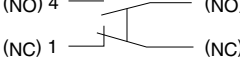
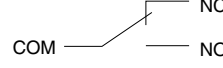
Type	TMS-BOX	1LS1-J WLCA2	1LX-7001	VCX-7003
Manufacturer	Tomoe	Azbil (1LS1-J) OMRON (WLCA2)	Azbil	Azbil
Circuit	Monopolar double-throw (1C, SPDT) X2 	Bipolar double interruption (1A1B, DPDT) 	Bipolar double interruption (1A1B, DPDT) 	Monopolar double-throw (1C, SPDT) X2 
Actuator	Hinge roller lever type	Roller lever type	Roller lever type	Adjustable roller lever type
Class of insulation	IP67 (Option: Exd IIBT6)	IP67	IP67, Exde IIC T6	IP67, Exde IIC T6
Rated voltage	AC250V-16A DC12V-0.6A	AC125V-10A AC250V-10A AC480V-10A DC125V-0.8A DC250V-0.4A	AC125V-5A AC250V-5A DC125V-0.8A DC250V-0.4A	AC250V-5A DC125V-0.8A DC250V-0.4A
Operating temperature	-10 to 80 degrees C	-10 to 80 degrees C	-10 to 60 degrees C	-10 to 60 degrees C
Conduit entry	2-G1/2	G1/2	G1/2	G3/4
Option	-	Heat, cold and corrosion resistant	Hydrogen anti-explosion (1LX5701)	Waterproof (VCL-5003)
Contacts	Switch detection with one (2 switches inside)	On or off detection with one Two for both on and off detection	On or off detection with one Two for both on and off detection	Switch detection with one (2 switches inside)
Weight	0.98kg	0.28kg	0.74kg	0.77kg

Remark: The above are standard TOMOE-compatible limit switches. It is also possible to install limit switches other than those listed above. For details, please consult us.

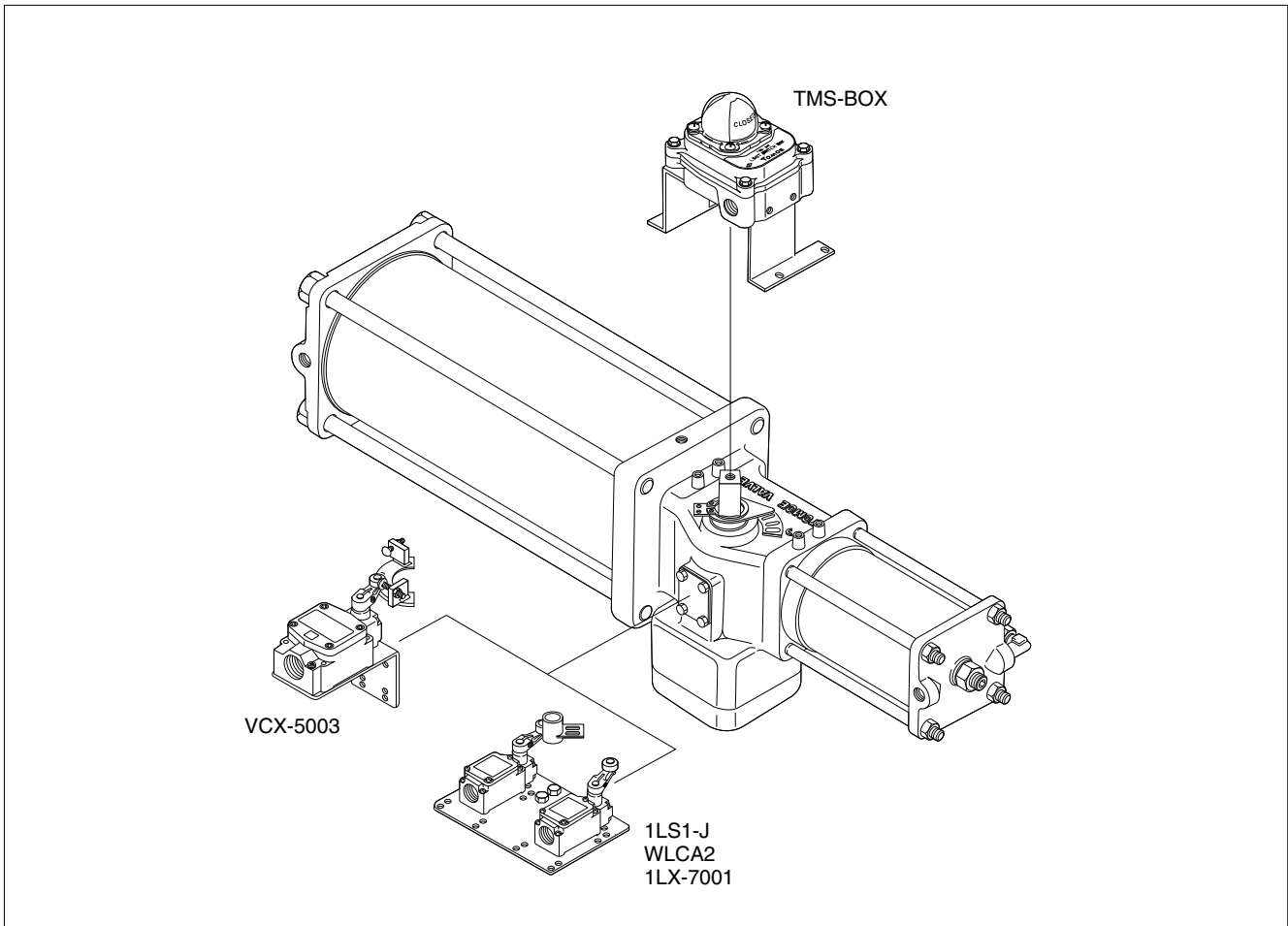

<b>Actuator</b>
<b>New ELMY 4I</b>
<b>New MICOM ELMY II 4I</b>
<b>PMK-SRF 4K</b>
<b>SRJ 4J</b>
<b>LTKD 4L</b>
<b>New T-DYNAMO 7E/7F/7G</b>
<b>TGA 3A</b>
<b>TG-S 3K/3U</b>
<b>3C</b>
<b>Diaphragm 6X/6W/6Z/6A/6B</b>
<b>Hydraulic cylinder 3H</b>
<b>Manual Actuators 1T/1J/2U/2I/2S/2G/2R</b>



## TG-S Proximity switches

### ■ Purpose

Proximity switches are used to convert the valve position (full close, full open, half open) into electric signals for lamp indication at a remote location.

### ■ Standard specifications

Product	M18 shielded type (Can be embedded in metal.)	M18 non-shielded type (Cannot be embedded in metal.)	M30 shielded type (Can be embedded in metal.)
Type	E2E-X7D1-N	E2E-X14MD1	E2E-X10D1-N
Manufacturer	OMRON	OMRON	OMRON
With power source	DC 2-wire system	DC 2-wire system	DC 2-wire system
Motion mode	NO	NO	NO
Detecting distance	0 to 5.6mm	0 to 11.2mm	0 to 8mm
Object to be detected	Magnetic metal (stainless steel possible)	Magnetic metal (stainless steel possible)	Magnetic metal (stainless steel possible)
Power source voltage	DC12 to 24V	DC12 to 24V	DC12 to 24V
Current consumption	3 to 100mA	3 to 100mA	3 to 100mA
Class of insulation	IP67	IP67	IP67
Operating temperature	-25 to 70 degrees C	-25 to 70 degrees C	-25 to 70 degrees C
Connection	Cord draw type (2m)	Cord draw type (2m)	Cord draw type (2m)
Contacts	On or off detection with one Two for both on and off detection	On or off detection with one Two for both on and off detection	On or off detection with one Two for both on and off detection
Weight	0.13kg	0.13kg	0.18kg

Remark: The above are standard TOMOE-compatible proximity switches. It is also possible to install limit switches other than those listed above such as a DC 3-wire, AC 2-wire, AC/DC 2-wire or connector-type proximity switch. For details, please consult us.

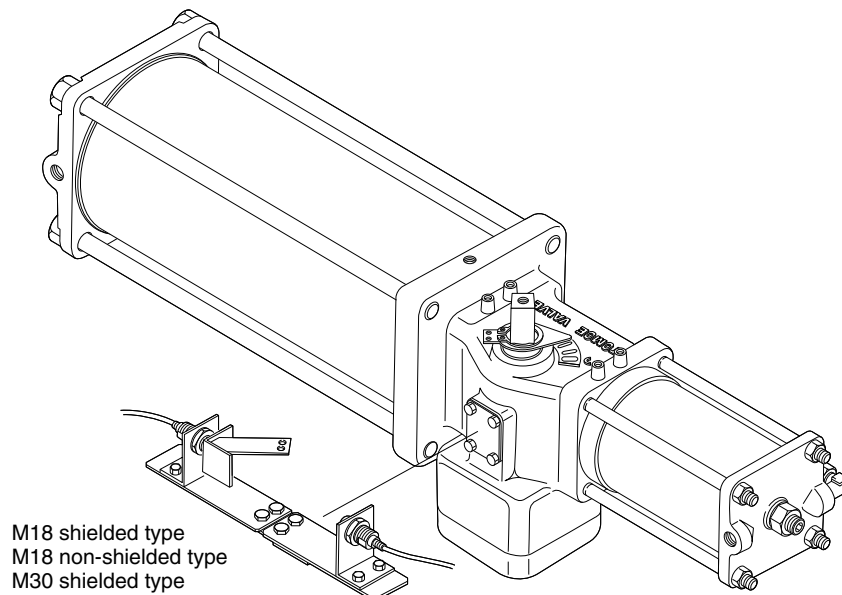

## TG-S Positioners

### ■ Purpose

Positioners are used for quick and accurate control of the valve opening angle with pneumatic signals or 4-20mA DC input signals from a control room or controller unit.

### ■ Standard specifications

	Electro-Pneumatic, analog	Electro-Pneumatic, analog	Electro-Pneumatic, digital (smart)	Pneumatic-Pneumatic
Type	TCE2000	TP8100	AVP300	IP5100
Manufacturer	Tomoe	Tomoe	Azbil	SMC
Input signal	4 to 20mA	4 to 20mA	4 to 20mA	0.02 to 0.1MPa
Resistance	250Ω (4 to 20mADC)	235±15Ω (4 to 20mADC)	300Ω (4 to 20mADC)	—
Supply air	0.14 to 0.7MPa	0.14 to 0.7MPa	0.14 to 0.7MPa	0.14 to 0.7MPa
Output flow rate	180L/min. or more (SUP=0.4MPa)	200L/min. or more (SUP=0.4MPa)	250L/min. or more (SUP=0.4MPa)	200L/min. or more (SUP=0.4MPa)
Air consumption	Within 11L/min. (SUP=0.4MPa)	Within 11L/min. (SUP=0.4MPa)	Within 10L/min. (SUP=0.4MPa)	Within 11L/min. (SUP=0.4MPa)
Operating temperature	-20 to 83 degrees C (Non explosion-proof) -20 to 60 degrees C (Explosion-proof type d2G4)	-20 to 8 degrees C (Non explosion-proof) -20 to 60 degrees C (Explosion-proof type d2G4)	-40 to 80 degrees C (Non explosion-proof) -20 to 60 degrees C (Explosion-proof type d2G4)	-20 to 80 degrees C
Class of insulation	IP65, ExdII BT6X	IP67, ExdII BT5	IP65 (option: Exd2CT6X)	—
Air connection port size	Rc1/4	Rc1/4	Rc1/4	Rc1/4
Conduit entry	2-G1/2	2-G1/2	2-G1/2	—
Sensitivity	Within 0.5%FS	Within 0.5%FS	Within 1%FS	Within 0.5%FS
Repeatability	Within ±1.5%FS	Within ±2%FS	Within ±1%FS	Within ±2%FS
Hysteresis	Within 1%FS	Within 1%FS	Within 1%FS	Within 1%FS
Option	—	—	Analog signal (4 to 20 mA) output Any special opening setting Supports field bus.	—
Weight	2.3kg	2.6kg	2.8kg	1.2kg

Remark: The above are standard TOMOE-compatible positioners. It is also possible to install positioners other than those listed above. For details, please consult us.

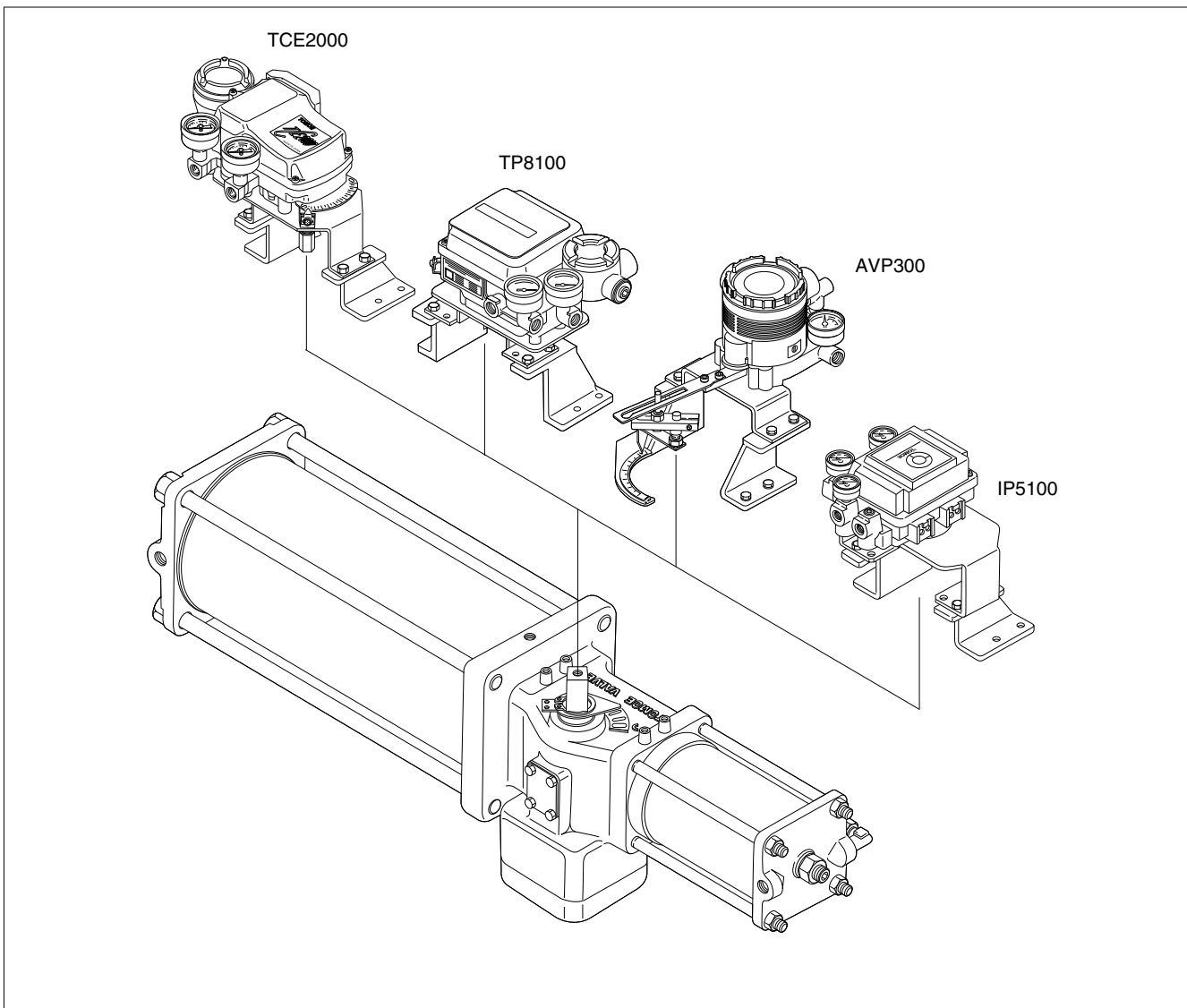

Actuator
<b>New ELMY</b> 4I
New MICOM ELMY II 4I
<b>PMK-SRF</b> 4K
<b>SRJ</b> 4J
<b>LTKD</b> 4L
New T-DYNAMO 7E/7F/7G
<b>TGA</b> 3A
<b>TG-S</b> 3K/3U
<b>3C</b>
<b>Diaphragm</b> 6X/6W/6Z/6A/6B
<b>Hydraulic cylinder</b> 3H
<b>Manual Actuators</b> 1T/1J/2U/2I/2S/2G/2R

## TG-S Manual operation unit

### ■ Purpose

The operation unit is for manual operation of the pneumatic cylinder when air supply fails.

### ■ Standard specifications

	Function	Type	Applicable cylinder	Remarks
1	Manual operation unit	Screw handle	Single acting type TG-S	(1) Attach and detach the lock screw exactly before and after operation. (2) Adjustment is possible in the full close position.

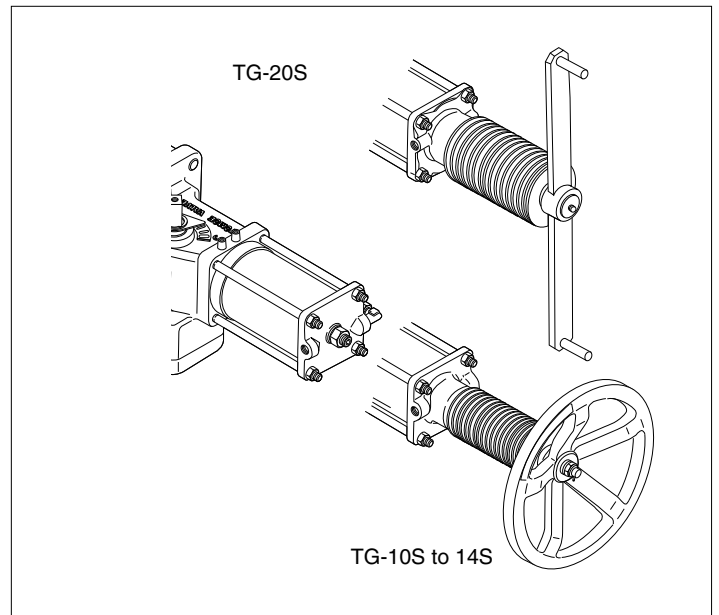

## TG-S Stroke adjusters

### ■ Purpose

The stroke adjuster sets the valve opening freely from the outside.

### ■ Standard specifications

Function	Type	Applicable cylinder	Remarks
Free opening unit	Side adjust screw	(A) Double acting type T-matic	After attaching a long adjustment bolt to the cylinder cover, attach the cover of the aluminium casing.
Adjust screw	Side adjust screw	(B) Double acting type TGA-100 (C) Single acting type T-matic	Attach long adjusting screws and lock nut to the cylinder cover.

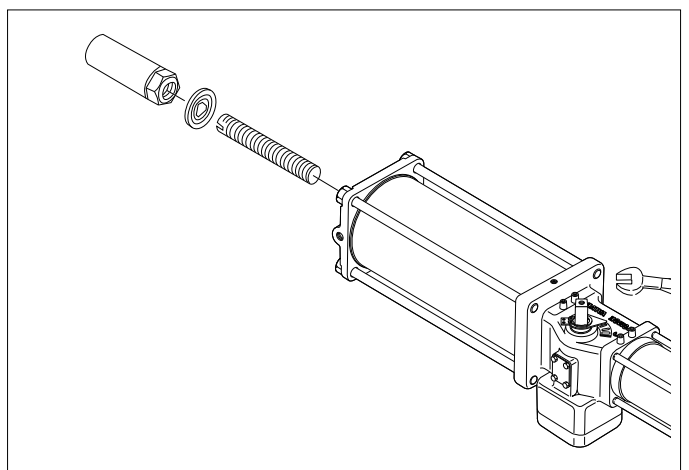

## TG-S Speed controllers

### ■ Purpose

For double-acting cylinders, the speed controller is used as meter out (exhaust throttle) and for single-acting cylinders, it is used as meter in (suction throttle).

### ■ Standard specifications

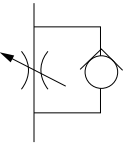
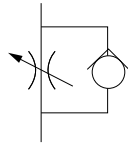
Type	AS3000-03	AS4000-04
Manufacturer	SMC	SMC
JIS symbol		
Applicable cylinder type	TG-10S to 14S	TG-20S
Needle revolution	8 rotations	8 rotations
Adjustable range	5 to 15 secs.	5 to 15 secs.
Operating temperature	-5 to 60 degrees C	-5 to 60 degrees C
Air connection port size	Rc3/8	Rc1/2
Attachment	Install to cylinder air connect port	Install to cylinder air connect port
Weight	0.13kg	0.21kg

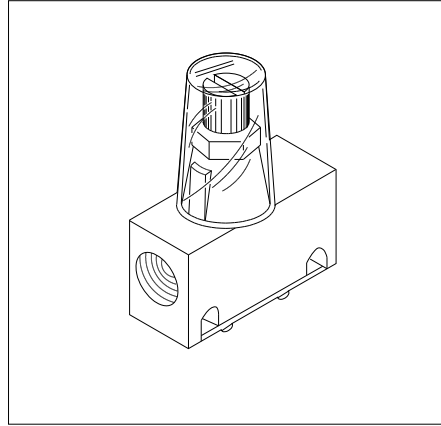



Remark: The above are standard TOMOE-compatible speed controllers. It is also possible to install speed controllers other than those listed above. For details, please consult us.

## TG-S Silencers

### ■ Purpose

Silencers eliminate noise at the exhaust ports on various kinds of pneumatic accessories.

### ■ Standard specifications

Type	AN20-02	AN30-03	AN40-04
Manufacturer	SMC	SMC	SMC
JIS symbol			
Effect of muffing	30dB (A)	30dB (A)	30dB (A)
Operating temperature	5 to 60 degrees C	5 to 6 degrees C	5 to 60 degrees C
Port size	Rc1/4	Rc3/8	Rc1/2
Attachment	Screw into exhaust port of solenoid valve.	Screw into exhaust port of cylinder and solenoid valve.	Screw into exhaust port of cylinder and solenoid valve.
Weight	0.02kg	0.03kg	0.04kg

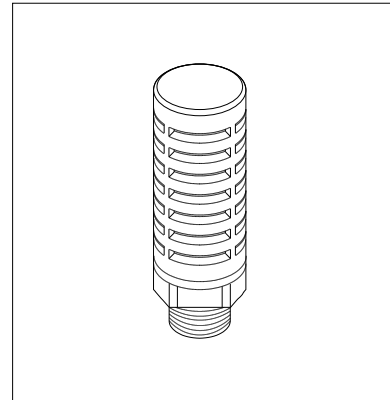

Remark: The above are standard TOMOE-compatible silencers. It is also possible to install silencers other than those listed above. For details, please consult us.

## TG-S Lock-up valves

### ■ Purpose

When air supply fails, the lock-up valve automatically stops the line until pressure is restored and keeps the operating unit of the cylinder at the stay-put position.

### ■ Standard specifications

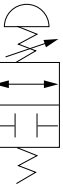
Type	IL201-02
Manufacturer	SMC
JIS symbol	
Effective sectional area	17mm <sup>2</sup>
Operating temperature	-5 to 60 degrees C
Air connection port size	Rc1/4
Signal pressure connection port	Rc1/4
Weight	0.43kg

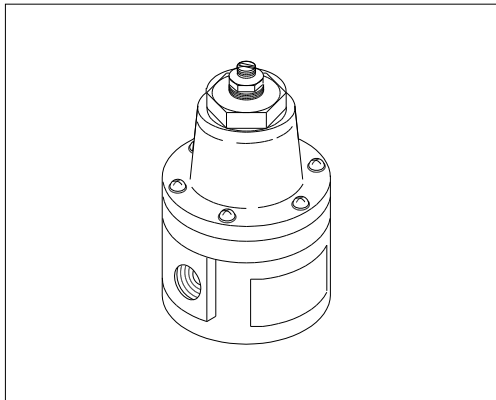

Remark: The above are standard TOMOE-compatible lock-up valves. It is also possible to install lock-up valves other than those listed above. For details, please consult us.

<b>Actuator</b>
<b>New ELMY 4I</b>
<b>New MICOM ELMY II 4I</b>
<b>PMK-SRF 4K</b>
<b>SRJ 4J</b>
<b>LTKD 4L</b>
<b>New T-DYNAMO 7E/7F/7G</b>
<b>TGA 3A</b>
<b>TG-S 3K/3U</b>
<b>3C</b>
<b>Diaphragm 6X/6W/6Z/6A/6B</b>
<b>Hydraulic cylinder 3H</b>
<b>Manual Actuators 1T/1J/2U/2I/2S/2G/2R</b>

Example of standard air circuit for on/off operation (single-acting type)

Shown below are examples of standard circuits to operate the valve automatically to the safe side of open or close when the operating air supply or power supply fails in the middle of operation.

- 1 Butterfly valve closes when air supply falls.  
 (Opened by pressure when solenoid valve is energized.)  
 Butterfly valve closes when power supply falls.  
 (Opened by pressure when solenoid valve is energized.)

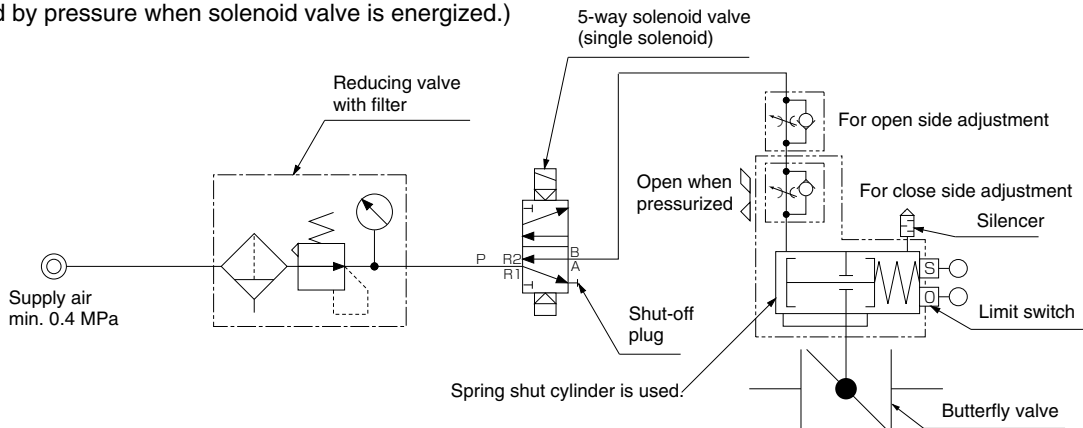

- 2 Butterfly valve opens when power supply falls.  
 (Closed by pressure when solenoid valve is energized.)  
 Butterfly valve opens when air supply falls.  
 (Closed by pressure when solenoid valve is energized.)

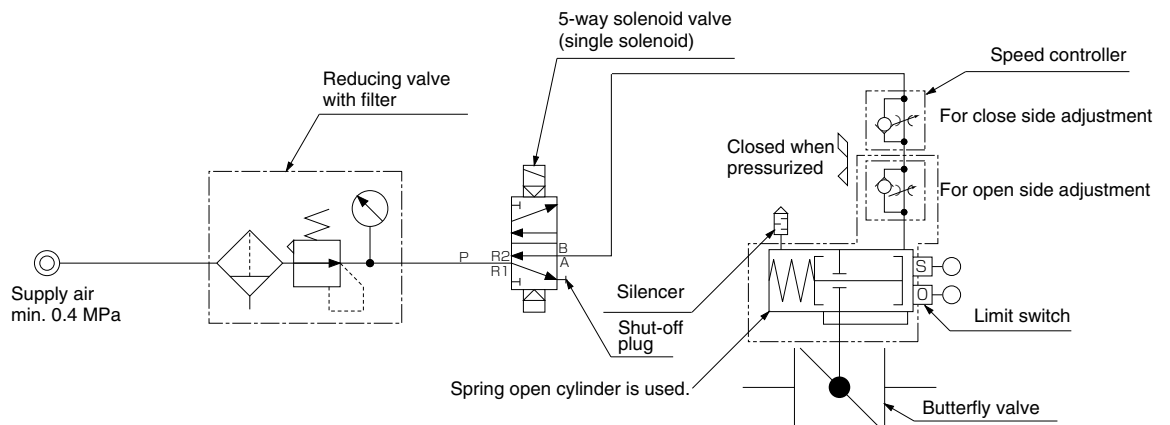

### Example of standard air circuit for control operation (single-acting type)

Shown below are examples of standard circuits in which the P/P or E/P positioner is attached to the butterfly valve driven by a single-acting pneumatic cylinder to adjust valve opening exactly and quickly in proportion to the signals transmitted by a local controller or from a remote control room. This will also detect the open/close position of the valve by a limit switch which sends feedback of the electric signals to the control room. When the operating air supply or power supply fails, the valve is automatically operated to the safe side of open or close.

#### 3 Direct action

Butterfly valve closes when signal increases.  
Butterfly valve opens when signal decreases.

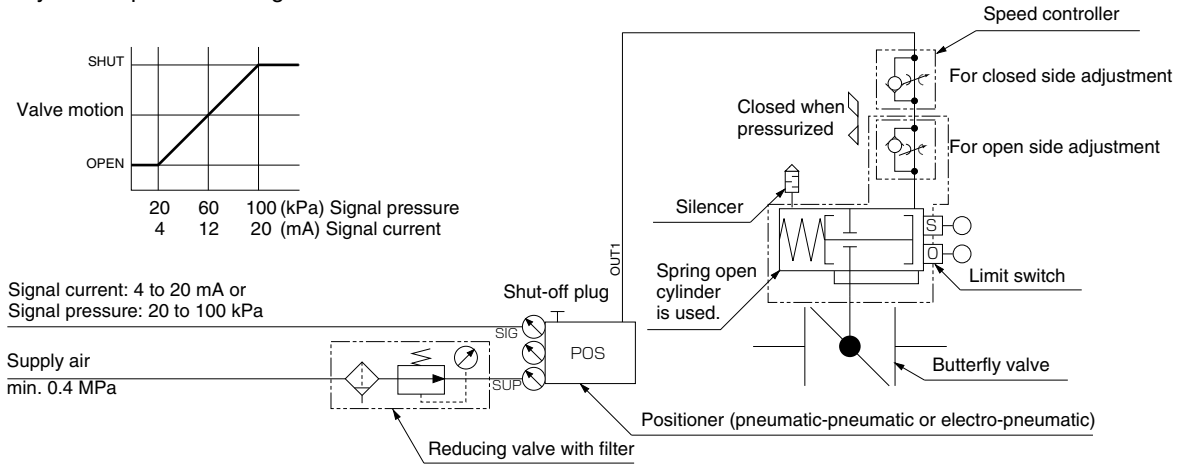

→Butterfly valve opens when air supply fails.

#### 4 Reverse action

Butterfly valve opens when signal increases.  
Butterfly valve closes when signal decreases.

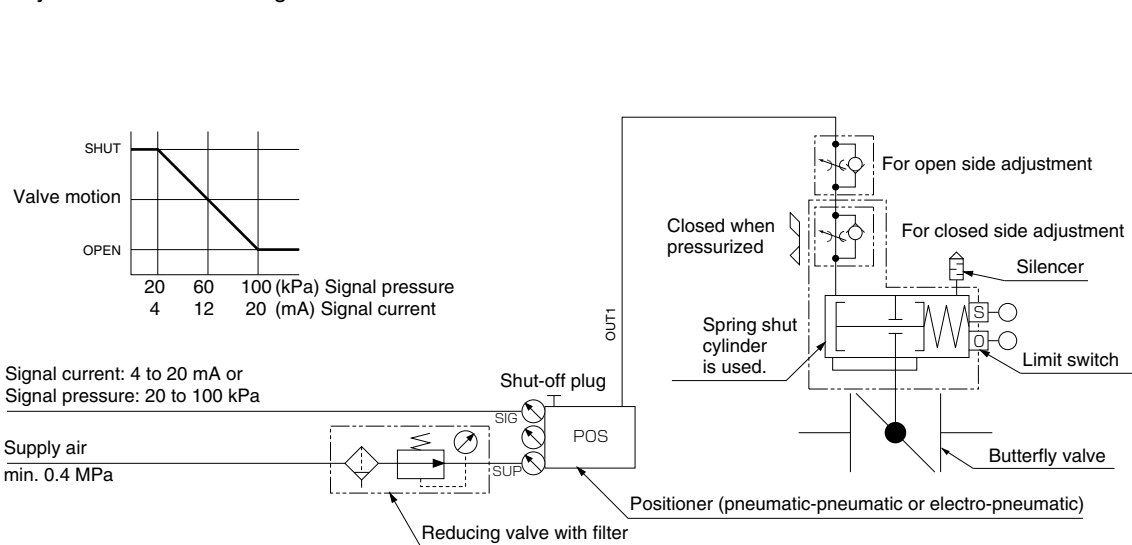

→Butterfly valve closes when air supply fails.

Actuator
<b>New ELMY</b> 4I
New MICOM ELMY II 4I
<b>PMK-SRF</b> 4K
<b>SRJ</b> 4J
<b>LTKD</b> 4L
New T-DYNAMO 7E/7F/7G
<b>TGA</b> 3A
<b>TG-S</b> 3K/3U
<b>3C</b>
<b>Diaphragm</b> 6X/6W/6Z/6A/6B
<b>Hydraulic cylinder</b> 3H
<b>Manual Actuators</b> 1T/1J/2U/2I/2S/2G/2R